

END SUCTION METRIC MODEL FM 65-200 A

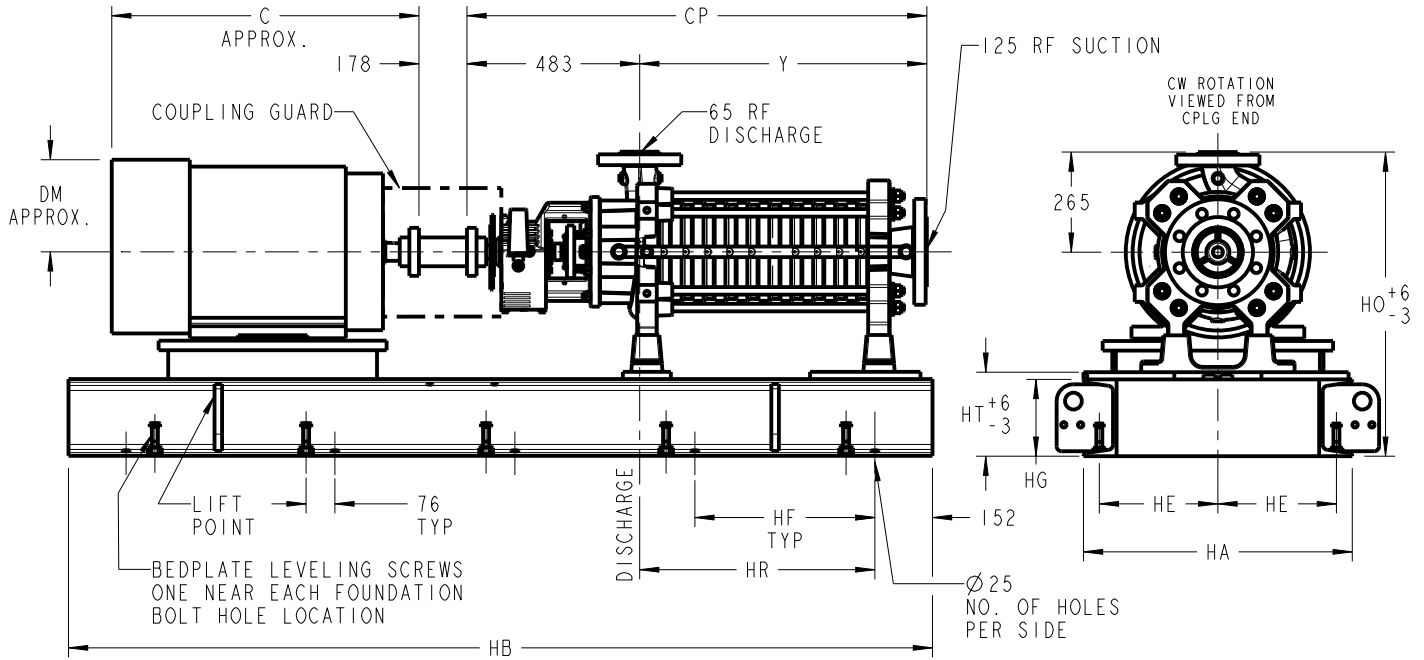

MOTOR DIMENSIONS (TEFC)					
NEMA	TEC	C	DM	WT. INCL. CPLG.	BASE CODE
256T	160L	610	168	123	
284T	180M	686	189	184	
284TS	-	660	189	179	
286T	180L	686	189	184	
286TS	-	660	189	179	
324T	200M	762	216	263	
324TS	-	737	216	254	
326T	200L	762	216	263	
326TS	-	737	216	254	
364T	225S	864	244	379	2
364TS	-	813	244	372	
365T	225M	864	244	379	
365TS	-	813	244	372	
404T	250S	991	271	526	
404TS	-	914	271	522	
405T	250M	991	271	526	
405TS	-	914	271	522	
444T	280S	1143	299	748	
444TS	-	1041	299	733	
445T	280M	1143	299	748	3
445TS	-	1141	299	733	
447T	-	1219	299	1025	
447TS	-	1194	299	1025	
449T	-	1346	299	1157	
449TS	-	1295	299	1157	

PUMP DIMENSIONS					
NO OF STAGES	Y	CP	HR	WT	PUMP CODE
2	238	720	394	221	A
3	296	778		245	A
4	354	836		268	A
5	412	894		292	A
6	470	952		316	A
7	528	1010		340	A
8	586	1068		364	B
9	644	1126		387	B
10	702	1184		404	B
11	760	1242		435	B
12	818	1300	459	C	
13	876	1358	813	482	C
14	934	1416	506	C	

BASEPLATE DIMENSIONS										
NO	HA	HB	HE	HF	HG	HO	HT	WT	NO. OF HOLES PER SIDE	
1A	610	2032	267	576	152	760	178	281	4	
2A	610	2032	267	576	152	760	178	294	4	
3A	711	2286	318	495	203	811	229	462	5	
1B	610	2286	267	495	203	811	229	372	5	
2B	610	2286	267	495	203	811	229	385	5	
3B	711	2540	318	559	203	811	229	478	5	
1C	711	2540	318	559	203	811	229	445	5	
2C	711	2540	318	559	203	811	229	445	5	
3C	711	2794	318	622	203	811	229	496	5	

▲SEE BELOW FOR ACTUAL DISCHARGE NOZZLE POSITION PROVIDED

INSTALL FOUNDATION BOLTS IN PIPE SLEEVES. ALLOW 25.4mm TO 50.08mm FOR GROUTING. SEE INSTRUCTION BOOK FOR DETAILS.

AVAILABLE OPTIONS	
FLANGES (RAISED FACE):	
DISC:	<input type="checkbox"/> 600# (ANSI B16.5)
	<input type="checkbox"/> 900# (ANSI B16.5)
	<input type="checkbox"/> PN-63 (EN 1092-1)
	<input type="checkbox"/> PN-100 (EN 1092-1)
SUCT:	<input type="checkbox"/> 150# (ANSI B16.5)
	<input type="checkbox"/> 300# (ANSI B16.5)
	<input type="checkbox"/> PN-40 (EN 1092-1)

▲POSITION OF DISCHARGE NOZZLE (VIEWED FROM SHAFT END)

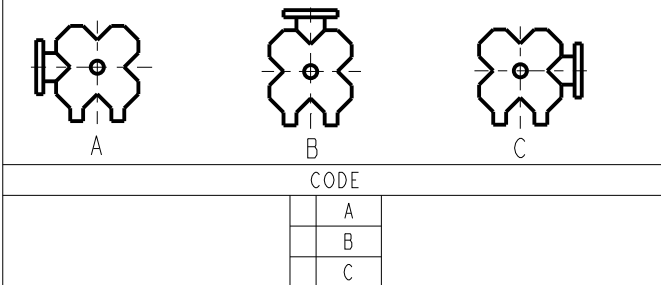

CERTIFIED FOR CONSTRUCTION PURPOSES ONLY WHEN SIGNED.

SIGNATURE

DATE

ISSUE

DRAWING IS NOT TO SCALE
DIMENSIONS IN MILLIMETERS
WEIGHTS(kg) ARE APPROXIMATE

DRAWN

DRAWING

REVISION

ISSUE

APPROVED

A10051A

4

--

FORM NO.

